



**LEAPTON**  
SOLAR

Monocrystalline

Polycrystalline

# LP182\*182-M-78-MH

Rated Power 580-605W

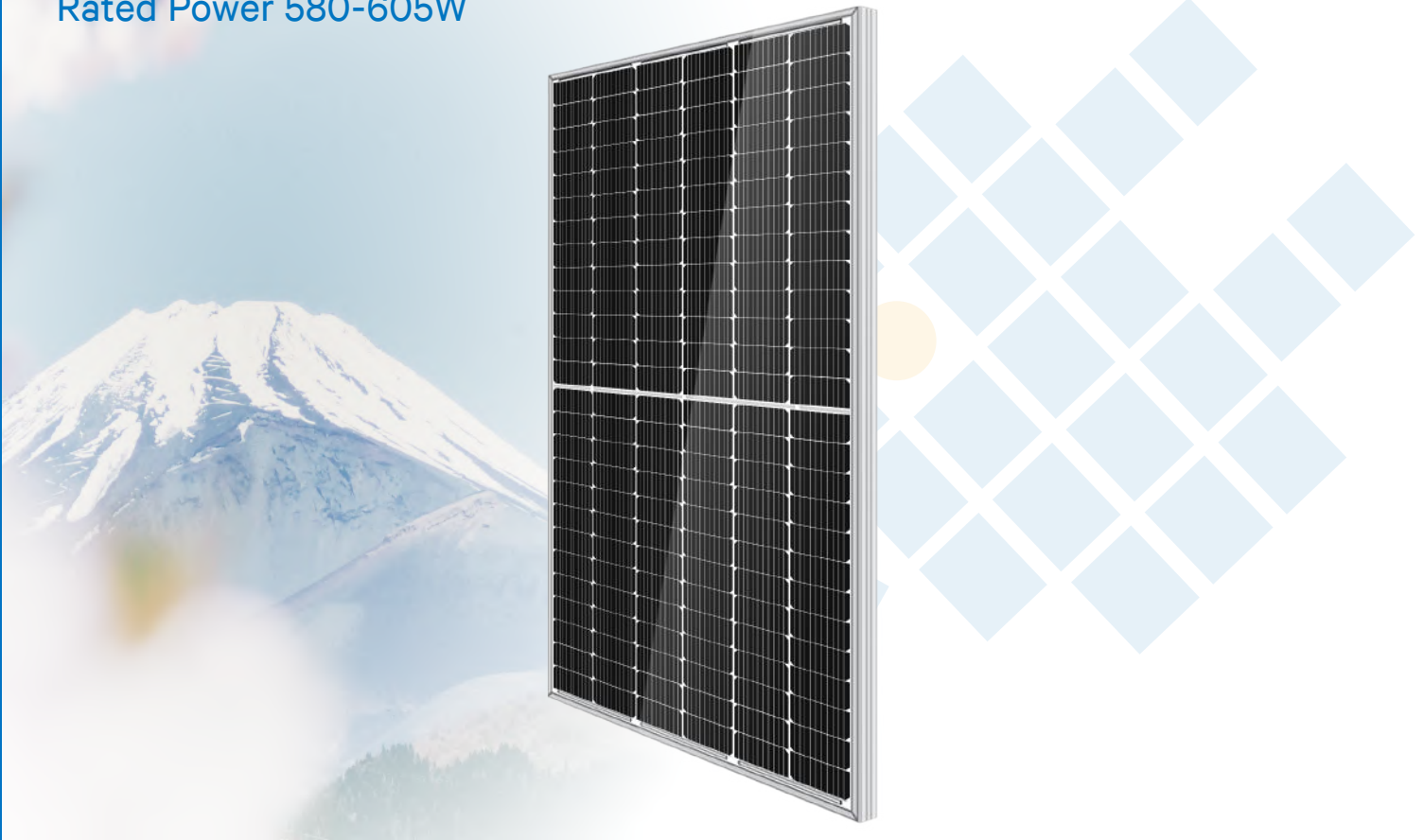

### MBB Cell

New circuit design, lower internal current, lower internal resistance loss.



### Low Light Features

Higher performance under low light environment.



### Higher Output Power

Module adopts 156 pcs of 182\*182mm half cells, the maximum power can reach 605W.



### PID Protection

Ensure the attenuation probability caused by PID phenomenon is minimized.



### Harsh Environmental Adaptability

Strict salt spray and ammonia corrosion test by TUV Nord.



### Load Capacity

Mechanical load tests including wind load 2400 Pa and snow load 5400 Pa done by TUV Nord.

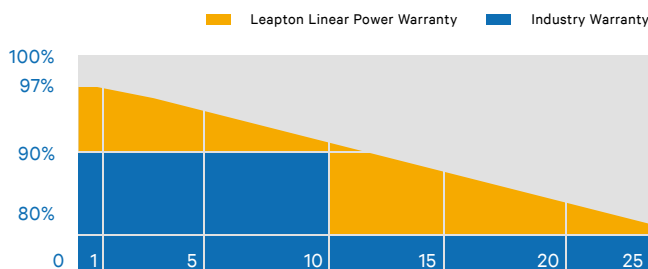

\*J-PEC Product



IEC 61215-2: 2016  
IEC 61730-2: 2016

Headquarter : Leapton Energy Co., Ltd.

📍 Tosei Bldg. 6F, 1-2-1 Aioi-cho, Chuo-ku Kobe-shi, Hyogo, 650-0025, Japan

☎ +81-78-382-3182

🌐 [www.leaptonenergy.jp](http://www.leaptonenergy.jp)

Manufacturer : Leapton Solar (Changshu) Co., Ltd.

📍 No.9, Sunshine Avenue, Changshu City, Jiangsu, China

☎ +86-512-88800068

✉ [info@leaptonenergy.com](mailto:info@leaptonenergy.com)

🌐 [www.leaptonpv.com](http://www.leaptonpv.com)

## MECHANICAL DIAGRAMS

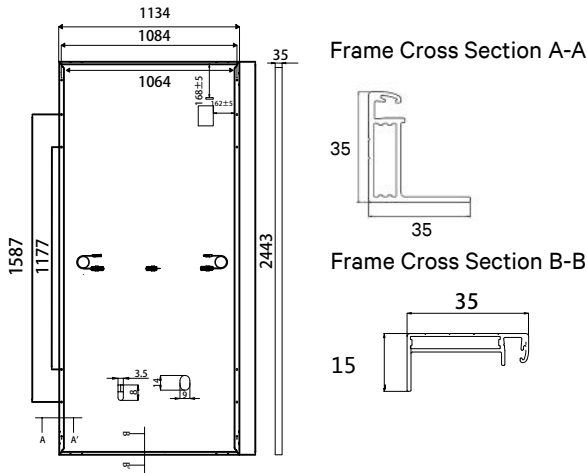

## SPECIFICATIONS

Weight	31kg
Dimensions	2443mm*1134mm*35mm
Cell Dimensions	182*182mm
Cell Amount	78*2 pcs
Maximum System Voltage	1500V
Junction Box	IP68
Frame	Aluminum Alloy
Cable	4mm <sup>2</sup> , Landscape: N 1500mm/P 1500mm Portrait: N 200mm/P 300mm
Connector	MC4 compatible
Application Level	Class A

## ELECTRICAL PARAMETERS AT STC

Power	580W	585W	590W	595W	600W	605W
Open Circuit Voltage	53.30V	53.50V	53.70V	53.90V	54.10V	54.30V
Short Circuit Current	13.81A	13.87A	13.94A	14.01A	14.08A	14.15A
Maximum Power Voltage	44.40V	44.60V	44.80V	45.00V	45.20V	45.40V
Maximum Power Current	13.07A	13.12A	13.17A	13.22A	13.27A	13.32A
Module Efficiency	20.94%	21.12%	21.30%	21.48%	21.66%	21.84%

\* Under Standard Test Conditions (STC) of irradiance of 1000 W/m<sup>2</sup>, spectrum AM 1.5 and cell temperature of 25°C.

## ELECTRICAL PARAMETERS AT NMOT

Power	428W	431W	435W	438W	442W	446W
Open Circuit Voltage	49.80V	50.00V	50.20V	50.40V	50.60V	50.80V
Short Circuit Current	11.13A	11.18A	11.23A	11.28A	11.33A	11.38A
Maximum Power Voltage	41.40V	41.60V	41.80V	42.00V	42.20V	42.39V
Maximum Power Current	10.32A	10.36A	10.41A	10.45A	10.50A	10.54A
Module Efficiency	15.45%	15.56%	15.70%	15.81%	15.95%	16.10%

\* Under Nominal Module Operating Temperature (NMOT), irradiance of 800 W/m<sup>2</sup>, spectrum AM 1.5, ambient temperature 20°C, wind speed 1 m/s.

## TEMPERATURE CHARACTERISTICS

NMOT	41±3°C	Temp Coefficient of ISC	+0.05%/°C
Temp Coefficient of VOC	-0.28%/°C	Temp Coefficient of Pmax	-0.36%/°C

## PACKING CONFIGURATION

Modules/Pallet	31 Pieces	Modules/40'Container	558 Pieces
Packing Description	17 Pallets, Total=(31+31)x9=558 Pieces		

## CHARACTERISTICS

LP182\*182-M-78-MH-580W

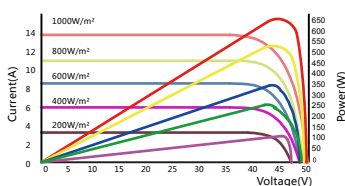

LP182\*182-M-78-MH-580W

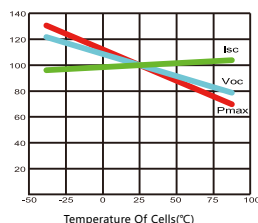

## MAXIMUM RATING

Output Tolerance	0~+5W
Operating Temperature	-40°C~+85°C
Wind Load/Snow Load	2400pa/5400pa
Fuse Current	25A

**15** YEARS  
Quality  
Warranty

**25** YEARS  
Power  
Warranty

Headquarter : Leapton Energy Co., Ltd.

☑ Tosei Bldg. 6F, 1-2-1 Aioi-cho, Chuo-ku Kobe-shi, Hyogo, 650-0025, Japan

☎ +81-78-382-3182

🌐 www.leaptonenergy.jp

Manufacturer : Leapton Solar (Changshu) Co., Ltd.

☑ No.9, Sunshine Avenue, Changshu City, Jiangsu, China

☎ +86-512-88800068

✉ info@leaptonenergy.com

🌐 www.leaptonpv.com